

# Parts catalogue

## FLAIL MOWER

(EXPORT MODEL)

### HRH801

MODEL	CODE NO.
HRH801	0225-ΔΔΔΔΔ

#### CONTENTS

Fig.1	HANDLE -----	1
Fig.2	TRANSMISSION -----	5
Fig.3	FRAME -----	9
Fig.4	ROTARY COVER -----	13

**OREC CO.,LTD.**

*Update : January 2006*

**Fig. 1 HANDLE**

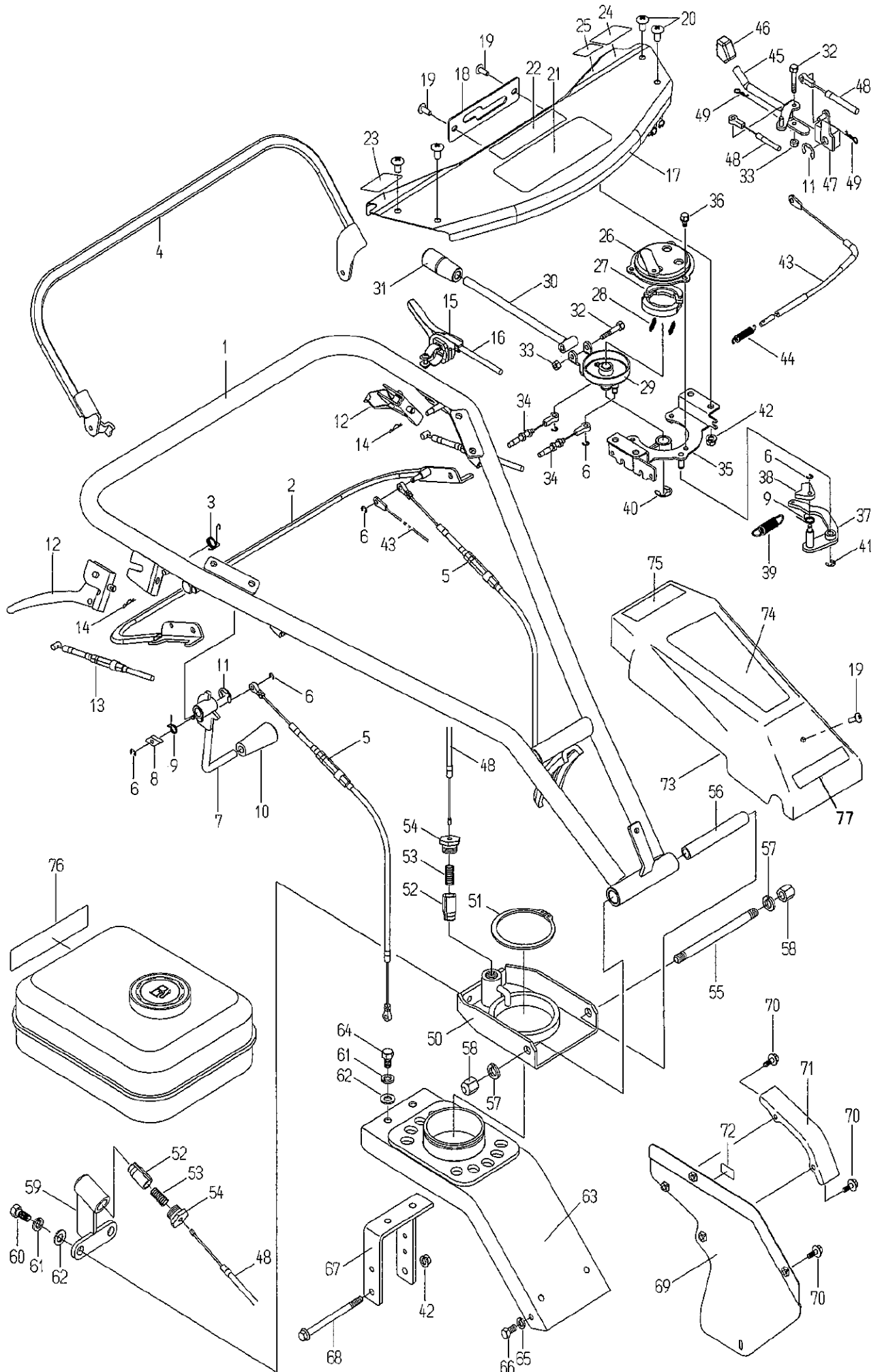

**FIG. 1 HANDLE**

Ref.	Parts No.	Parts Name	Quantity	Remarks
			HRH	
			801 FE290D	
1	0225-10100	Handle CMP	1	
2	0225-10200	Driving Clutch Lever	1	
3	0225-11900	Knife Clutch Lever Return Spring	1	
4	0225-10300	Knife Clutch Lever	1	
5	83-1614-932-00	Wire, Tension	2	
6	89-2521-000050	E-type Ring 5	6	
7	0225-11600	Driving Tension Lever	1	
8	80-1417-253-00	Stopper	1	
9	0211-70400	Stopper return spring	2	
10	80-1417-255-00	Lever Grip(Red) 10	1	
11	89-2521-000100	E Type Ring 10	2	
12	83-1761-457-00	Side Clutch Lever	2	
13	83-1614-962-00	Wire, Side Clutch	2	
14	89-2131-080002	Snap Pin 8	2	
15	83-1260-461-00	Throttle Lever	1	
16	0201-70900	Wire, Throttle	1	
17	0225-10400	Control Cover	1	
18	0225-10900	Change Guide	1	
19	89-1159-060168	Truss Mini Screw M6*16	3	
20	89-1159-080168	Truss Mini Screw M8*16	4	
21	0225-70600	Label, HST	1	
22	0225-70400	Label, Change	1	
23	0225-71400	Label, Blade	1	
24	0225-71500	Label, Driving	1	
25	80-1321-916-00	Label, Handle Up/Down/Right/Left Wire	1	
26	80-1614-314-00	Brake Cover	1	
27	85-1711-316-00	Brake Shoe	2	
28	85-1711-317-00	Shoe Return Spring	2	
29	0225-10600	Change Drum	1	
30	0225-10700	Change Lever	1	
31	83-1210-425-00	Lever Grip 10	1	
32	89-1111-060402	Hexagonal Bolt M6*40	2	
33	89-1551-060002	Hexagonal U Nut M6	2	
34	0225-70200	Wire, Change	2	
35	0225-10500	Change Brake Attachment	1	
36	89-1132-060122	Hexagonal Bolt (SW) M6*12	3	
37	0225-10800	Change Return Arm	1	
38	0225-11700	Change Stopper	1	
39	0208-71800	Spring, Neutral	1	
40	89-2521-000120	E Type Ring 12	1	
41	89-2521-000070	E Type Ring 7	1	
42	89-1543-080002	Mini Hexagonal Nut (SW) M8	5	
43	0225-70100	Wire, Change Brake	1	
44	0225-11800	Spring, Change Brake	1	
45	0225-11100	Lever	1	
46	80-1761-291-00	Lever Cap	1	
47	80-1321-245-00	Lever Arm	1	
48	83-1761-965-00	Handle Wire	2	
49	89-2131-060002	Snap Pin 6	2	
50	80-1310-203-00	Turntable for Handle	1	
51	89-2511-000850	Snap Ring 85	1	



FIG. 1 HANDLE

Ref.	Parts No.	Parts Name	Quantity	Remarks
			HRH	
			801 FE290D	
52	80-1210-216-00	Stopper Pin	2	
53	80-1210-217-00	Stopper Spring	2	
54	80-1310-215-00	Stopper Cap	2	
55	83-1213-133-00	Setting Bolt M12*160	1	
56	80-1210-222-00	Handle Setting Collar	1	
57	89-1750-120002	Spring Washer 12	2	
58	80-1310-228-00	Handle Fix Nut	2	
59	80-1330-214-10	Stopper for Handle Up/Down	1	*9)
	<b>80-1445-214-10</b>	<b>Stopper for Handle Up/Down</b>	<b>1</b>	<b>*1) *10)</b>
60	89-1211-100202	Mini Hexagonal Bolt M10*20	2	
61	89-1750-100002	Spring Washer 10	4	
62	89-1711-100002	Flat Washer 10	4	
63	80-1614-732-20	Under Bonnet CMP	1	
64	89-1211-100162	Mini Hexagonal Bolt M10*16	2	
65	89-1750-080002	Spring Washer 8	2	
66	89-1213-080162	Mini Hexagonal Bolt (8T) M8*16	2	
67	0225-11300	Under Bonnet Setting	1	
68	89-1253-080853	Flange Hexagonal Bolt (8T) M8*85	1	
69	0225-60100	Side Cover	1	
70	89-1131-060152	Hexagonal Bolt(PW) 6*15	5	
71	0225-60200	Sub Side Cover	1	
72	83-1712-923-00	Label, Oil Quantity 1.6 L	1	
73	0225-11200	Handle Bonnet	1	
74	0225-70500	Label, Bonnet	1	
75	0225-70700	Label, Model	1	
76	83-1415-909-00	Label, Caution for Engine etc	1	*5)
	0223-76200	Label, Caution for Engine etc	1	*1) *6)
77	83-1310-902-00	OREC Mark	1	

MEMO

\*1)Interchangeable

\*2)Serial Number : Before YH02D00001

\*3)Serial Number : YH02D00001~

\*4)Serial Number : YH03H00010~

\*5)Serial Number : ~YH03M00080

\*6)Serial Number : YH03M00081~

\*7)Serial Number : ~YH05A00074

\*8)Serial Number : YH05B00001~

\*9)Serial Number : ~YH05H00021

\*10)Serial Number : YH05K00021~

**Fig. 2 TRANSMISSION**

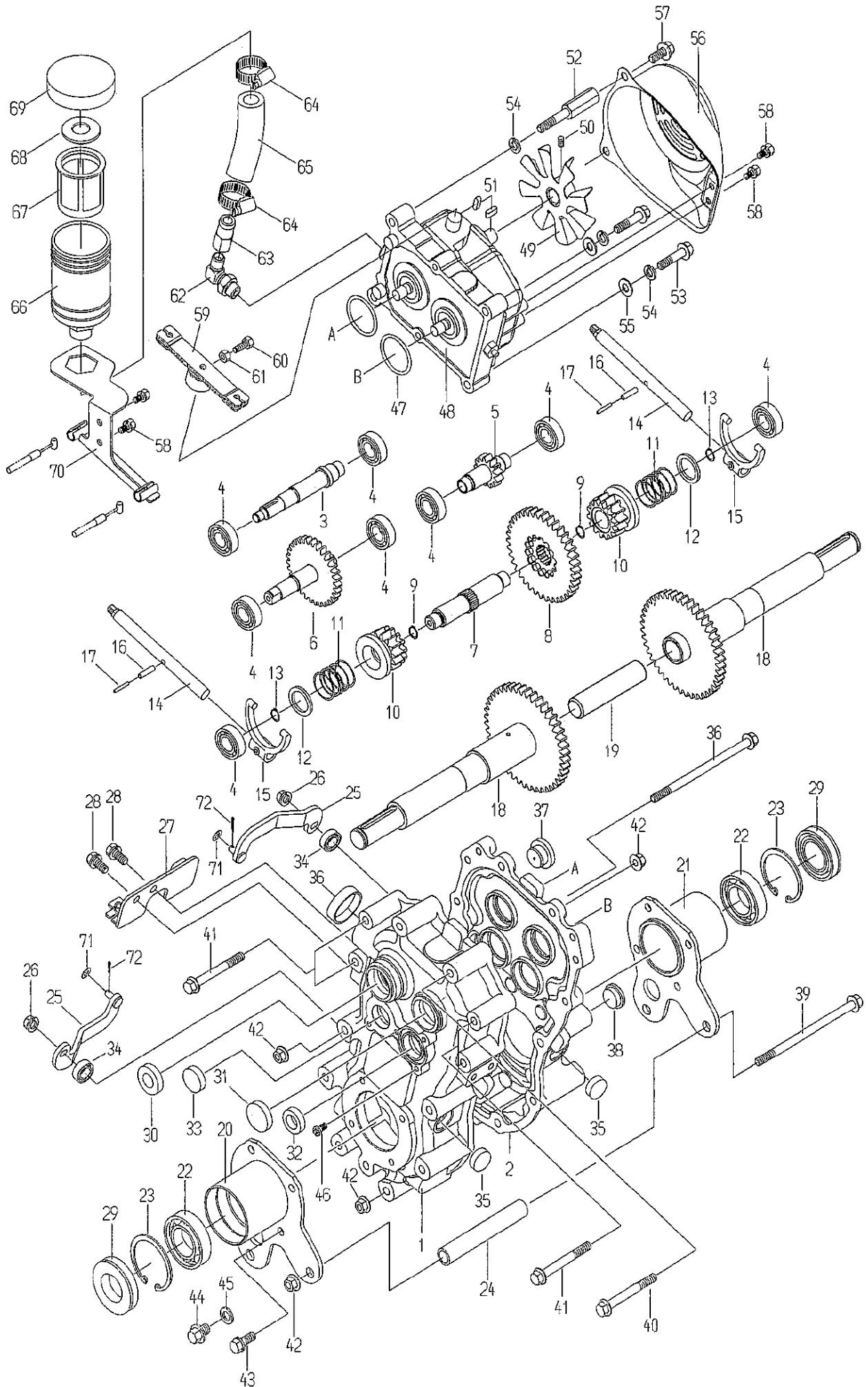

**FIG. 2 TRANSMISSION**

Ref.	Parts No.	Parts Name	Quantity	Remarks
			HRH	
			801 FE290D	
1~46	0225-01000	Transmission Case Assy	1	
1	0225-00100	Transmission Case (R)	1	
2	0225-00200	Transmission Case (L)	1	
3	0225-00300	B Axle	1	
4	89-3111-062024	Bearing 6202	8	
5	0225-00400	C Axle	1	
6	0225-00500	D Axle	1	
7	80-1032-140-00	Side Clutch Shaft	1	
8	80-1575-142-00	Side Clutch Gear 38T	1	
9	89-2511-000200	Snap Ring 20	2	
10	80-1032-141-00	Side Clutch Gear 14T	2	
11	80-1575-162-00	Side Clutch Spring	2	
12	83-1633-362-10	Thrust Washer 15x30x1.2	2	
13	89-2511-000150	Snap Ring 15	2	
14	80-1425-112-00	Driving Clutch Folk Shaft	2	
15	80-1415-114-00	Side Clutch Folk	2	
16	89-2111-050020	Spring Pin 5x20	2	
17	89-2111-030020	Spring Pin 3x20	2	
18	0204-00100	Axle CMP	2	
19	80-1310-150-10	Shaft Pin	1	
20	0225-00600	Shaft BB Case (R)	1	
21	0225-00700	Shaft BB Case (L)	1	
22	89-3111-060064	Bearing 6006	2	
23	89-2512-000550	Snap Ring 55	2	
24	0225-01800	Reinforcement Pipe	2	
25	80-1565-153-00	Side Clutch Arm	2	
26	89-1543-080002	Mini Hexagonal Nut(SW) M8	2	
27	0225-00900	Receiver for Side Clutch Wire	1	
28	89-1232-080162	Mini Hexagonal Bolt (SW) M8*16	2	
29	83-1415-662-00	Oil Seal AP 35.55.8	2	
30	89-5121-153007	Oil Seal UE 15.30.7	1	
31	83-1415-672-00	Blind Cover 30	1	
32	89-5121-152507	Oil Seal UE 15.25.7	1	
33	0225-70900	Blind Cover 25	1	
34	89-5121-122207	Oil Seal UE 12x22x7	2	
35	83-1415-671-00	Blind Cover 22	2	
36	0225-70800	Blind Cover 40	1	
37	83-1517-685-00	Oil Cap 20	1	
38	0225-71100	Oil Gauge 20	1	
39	89-1253-081403	Small Flange Bolt (8T)M8*140	5	
40	89-1253-080703	Small Flange Bolt (8T)M8*70	1	
41	89-1253-080653	Small Flange Bolt (8T)M8*65	4	
42	83-1484-255-00	Rock Nut ZUF M8	6	
43	89-1232-080182	Mini Hexagonal Bolt (SW) M8*18	8	
44	89-1251-100122	Flange Hexagonal Bolt M10*12	1	
45	83-1020-349-00	Copper Packing 10	1	
46	89-1151-060103	Crossrecessed Headed Screw M6*10	3	
47	89-5222-040000	O Ring G45	2	
48	0225-02100	HST Unit	1	
49	0225-02200	Fan	1	
50	89-1172-060065	Hexagonal Hole Screw M6*6	1	

**Fig. 2 TRANSMISSION**

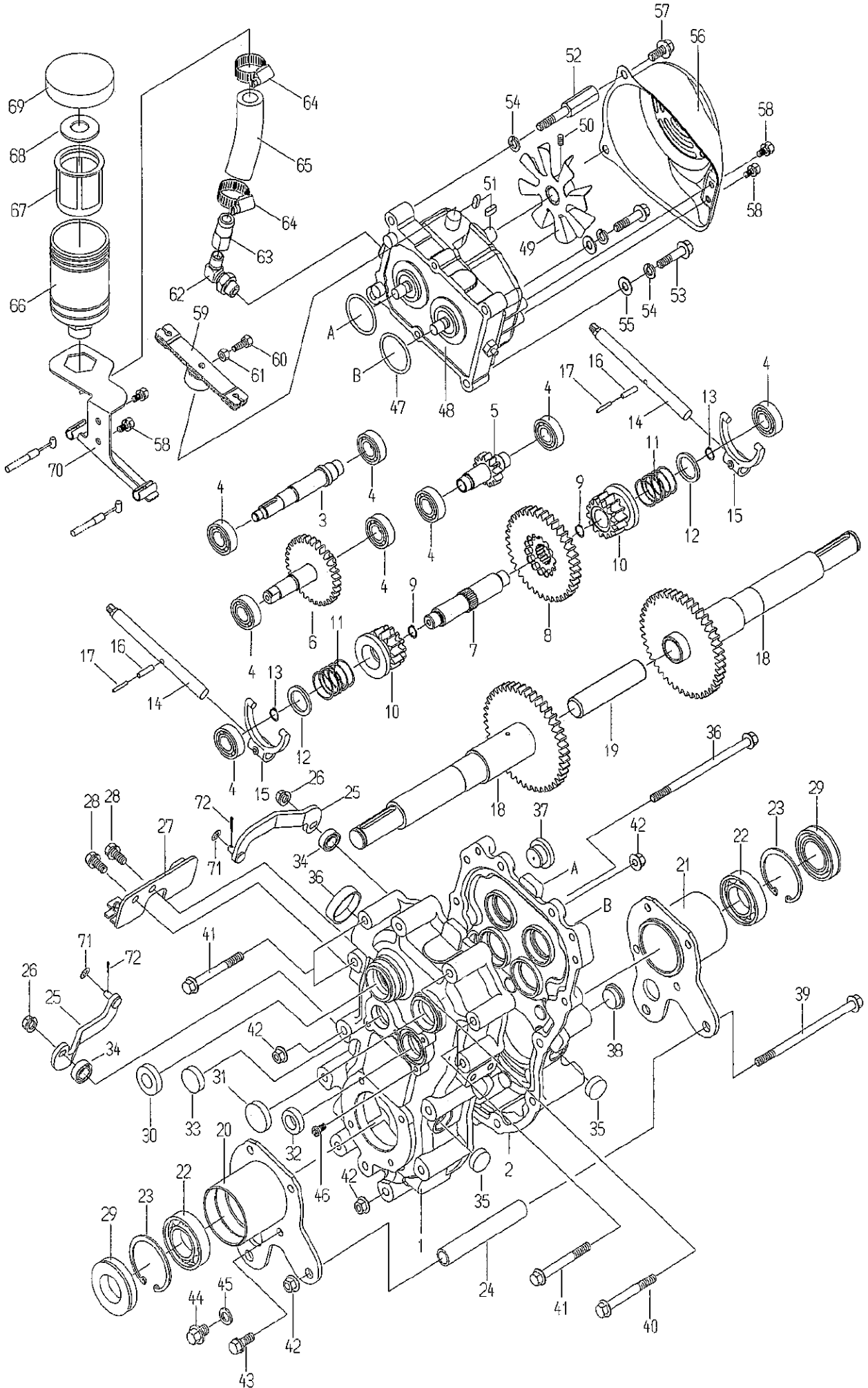



**FIG. 2 TRANSMISSION**

Ref.	Parts No.	Parts Name	Quantity	Remarks
			HRH	
			801 FE290D	
51	89-2150-050150	Key 5*15(round)	2	
52	0225-02300	Fan Cover Setting Bolt M8	1	
53	89-1253-080402	Flange Hexagonal Bolt (8T) M8*40	2	
54	89-1750-080002	Spring Washer 8	4	
55	89-1711-080002	Flat Washer 8	2	
56	0225-01110	Fan Cover CMP	1	
57	89-1233-080162	Mini Hexagonal Bolt (PWSW) M8*16	2	
58	89-1132-060122	Hexagonal Bolt (SW) M6*12	4	
59	0225-00800	Control Arm CMP	1	
60	89-1113-060162	Hexagonal Bolt (8T) M6*16	1	
61	89-1511-060042	Hexagonal Nut M6	1	
62	0225-01500	Port Joint	1	
63	0225-01600	Port Joint Adapter	1	
64	0207-08100	Horse Band 30	2	*7)
	<b>0228-70200</b>	<b>Horse Band 24</b>	<b>2</b>	<b>*8)</b>
<b>65</b>	<b>0225-01900</b>	<b>Oil Horse</b>	<b>1</b>	
66	0207-07620	Oil Tank	1	
67	0207-71300	Filter(with level)	1	
68	0207-08400	Cap Packing	1	
69	0207-08300	Oil Tank Cap	1	
70	0225-01700	Receiver for Change Wire	1	
71	89-1711-060002	Flat Washer 6	2	
72	89-2120-200152	Split Pin 2*15	2	

MEMO

- \*1)Interchangeable
- \*2)Serial Number : Before YH02D00001
- \*3)Serial Number : YH02D00001~
- \*4)Serial Number : YH03H00010~
- \*5)Serial Number : ~YH03M00080
- \*6)Serial Number : YH03M00081~
- \*7)Serial Number : ~YH05A00074
- \*8)Serial Number : YH05B00001~
- \*9)Serial Number : ~YH05H00021
- \*10)Serial Number : YH05K00021~

**Fig. 3 FRAME**

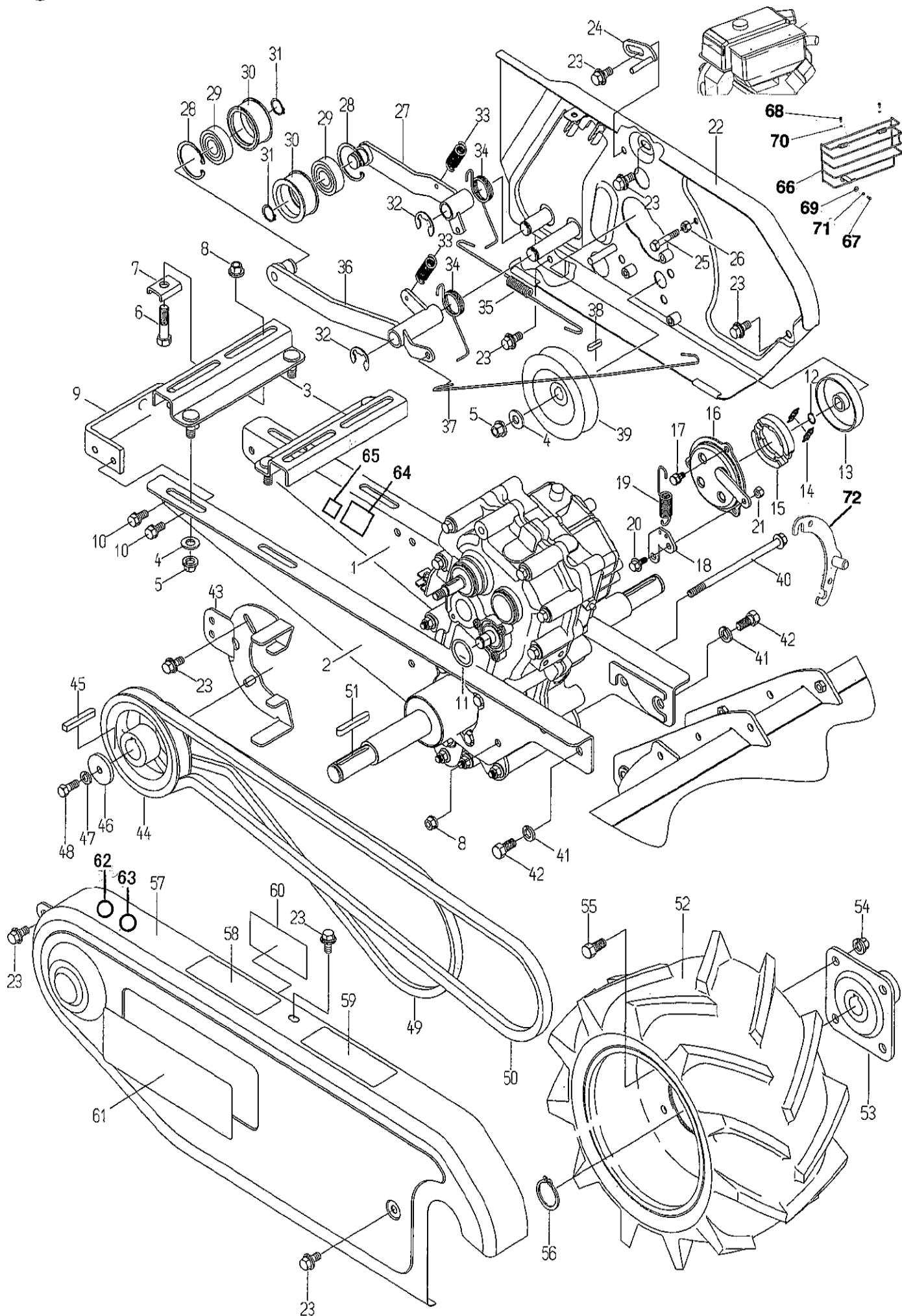

**FIG. 3 FRAME**

Ref.	Parts No.	Parts Name	Quantity	Remarks
			HRH	
			801 FE290D	
1	80-1614-301-20	Main Frame(L) CMP	1	
2	80-1614-302-20	Main Frame(R) CMP	1	
3	0211-30100	Engine Fitting Plate with Bolt	2	
4	89-1711-100002	Flat Washer	5	
5	89-1543-100002	Mini Hexagonal Nut(SW) M10	5	
6	89-1213-080402	Mini Hexagonal Bolt (8T) M8*40	4	
7	83-1210-388-00	Whirl Stop Plate B8	4	
8	89-1543-080002	Mini Hexagonal Nut(SW) M8	7	
9	80-1415-326-00	Rear Bracket	1	
10	89-1232-080162	Mini Hexagonal Bolt (SW) M8*16	6	
11	89-5222-030000	O Ring G30	1	
12	89-2511-000140	Snap Ring 14	1	
13~16	80-1614-310-00	Brake ASSY	1	
13	85-1711-315-00	Brake Drum	1	
14	85-1711-317-00	Shoe Return Spring	2	
15	85-1711-316-00	Brake Shoe	2	
16	80-1614-314-00	Brake Cover	1	
17	89-1132-060122	Hexagonal Bolt (SW) M6*12	3	
18	0225-30200	Brake Support Arm	1	
19	0223-72200	Brake Pulling Spring	1	
20	89-1131-060152	Hexagonal Bolt (PW) M6*15	1	
21	89-1551-060002	Hexagonal U Nut M6	1	
22	0225-40400	Belt Cover Inside CMP	1	
23	89-1233-080162	Mini Hexagonal Bolt (PW SW) M8*16	9	
24	0225-40600	Belt Holder	1	
25	89-1113-060352	Hexagonal Bolt (8T) M6*35	1	
26	89-1511-060042	Hexagonal Nut M6	1	
27	0225-40300	Driving Tension Arm	1	
28	89-2512-000400	Snap Ring 40	2	
29	89-3115-062034	Bearing 6203 2RS	2	
30	83-1032-765-00	Tension Pulley	2	
31	89-2511-000170	Snap Ring 17	2	
32	89-2521-000150	E-type Ring 15	2	
33	80-1560-551-00	Return Spring	2	
34	80-1614-552-00	Tension Spring	2	
35	0225-40800	Drive Brake Pulling Spring	1	
36	80-1614-546-10	Knife Tension Arm	1	
37	80-1614-374-30	Brake Rod	1	
38	89-2150-050200	Key 5x20	1	
39	0225-40200	Transmission Pulley	1	
40	89-1251-081453	Flange Hexagonal Bolt M8*145	3	
41	89-1750-100002	Spring Washer 10	4	
42	89-1213-100202	Mini Hexagonal Bolt (8T) M10*20	4	
43	0225-40500	Belt Holder	1	
44	0225-40100	Engine Pulley	1	
45	89-2151-070400	Key 7x40	1	
46	83-1565-315-00	Washer 8x36x4.5	1	
47	89-1750-080002	Spring Washer 8	1	
48	89-1213-080202	Mini Hexagonal Bolt (8T) M8*20	1	
49	89-6122-004102	V Belt SA-41 W800	1	
50	89-6123-006202	V Belt SB-62 W800	1	

**Fig. 3 FRAME**

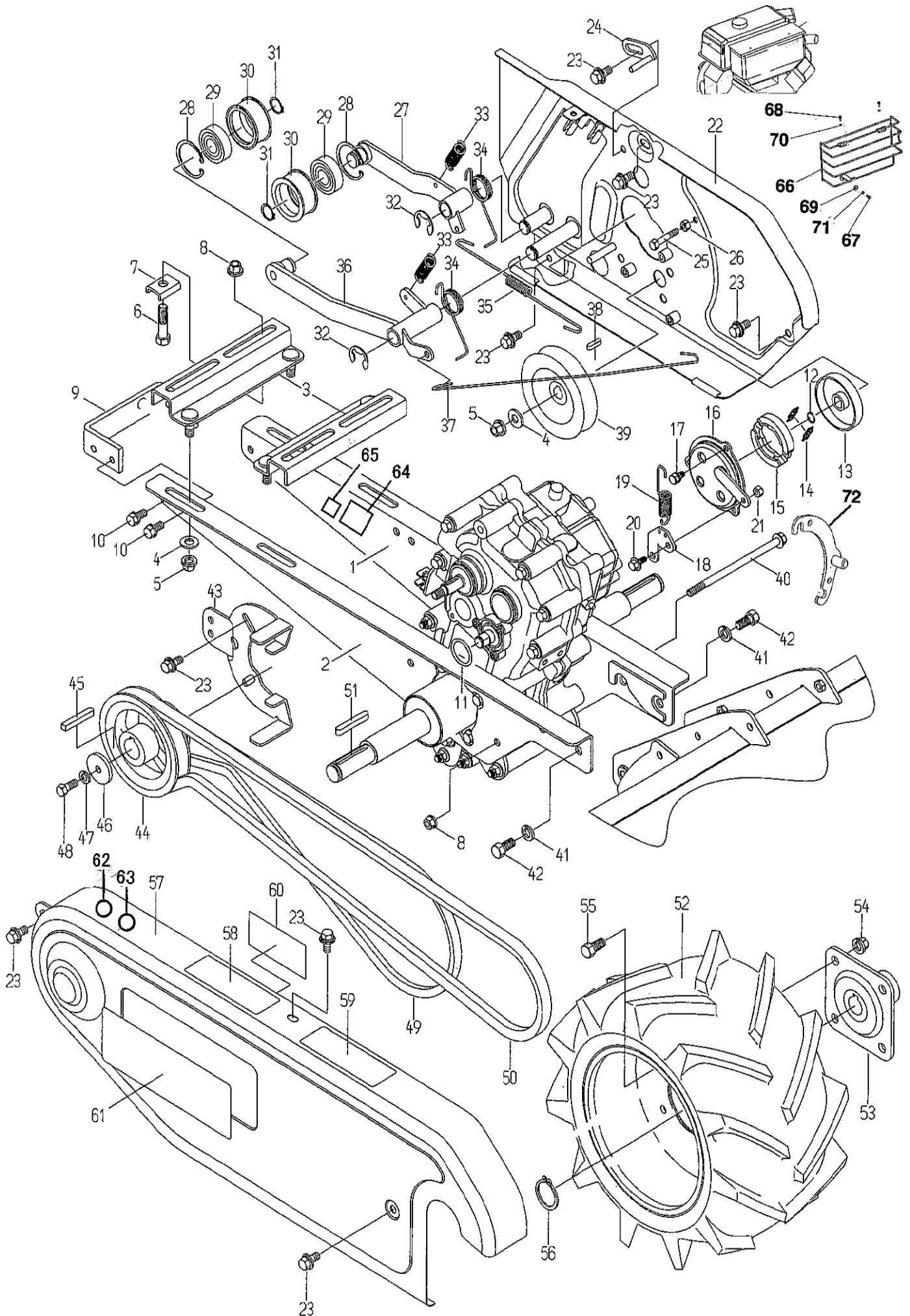

FIG. 3 FRAME

Ref.	Parts No.	Parts Name	Quantity	Remarks
			HRH	
			801 FE290D	
51	89-2150-070500	Key 7x50	2	
52	80-1751-412-00	Tire(R) ASSY	1	
53	80-1751-411-00	Tire(L) ASSY	1	
54	80-1565-413-00	Wheel Boss	2	
55	89-1543-100002	Mini Hexagonal Nut(SW) M10	8	
55	89-1211-100202	Mini Hexagonal Bolt M10*20	8	
56	89-2511-000220	Snap Ring 22	2	
57	80-1614-504-20	Belt Cover CMP	1	
58	83-1260-908-00	Label, Caution for Back	1	*5)
59	80-1488-928-00	Label, Caution for Pinching	1	*5)
	80-1488-928-10	Label, Caution for Pinching	1	*1) *6)
60	0225-71600	Label, Belt Size	1	
61	80-1614-905-00	Label, Belt Case	1	
62	0223-72900	Attention Mark for Slope	1	*6)
	0223-72910	Attention Mark for Slope	1	*1)
63	0215-83200	Label, Protection Equipment	1	*6)
64	80-1020-932-00	Label, Noise 100db	1	
65	80-1010-933-00	Label, CE	1	
66	0223-60700	Muffler Guard CMP	1	*4)
67	89-1113-060162	Hexagonal Bolt (8T) M6*16	1	*4)
68	89-1251-050123	Flange Hexagonal Bolt M5*12	2	*4)
69	89-1713-060002	Flat Washer 6	1	*4)
70	89-1750-050003	Spring Washer 5	2	*4)
71	89-1750-060002	Spring Washer 6	1	*4)
<b>72</b>	<b>0225-40900</b>	<b>Brake Stopper CMP</b>	<b>1</b>	<b>*10)</b>

MEMO

\*1)Interchangeable

\*2)Serial Number : Before YH02D00001

\*3)Serial Number : YH02D00001~

\*4)Serial Number : YH03H00010~

\*5)Serial Number : ~YH03M00080

\*6)Serial Number : YH03M00081~

**\*7)Serial Number : ~YH05A00074**

**\*8)Serial Number : YH05B00001~**

**\*9)Serial Number : ~YH05H00021**

**\*10)Serial Number : YH05K00021~**

**Fig. 4 ROTARY COVER**

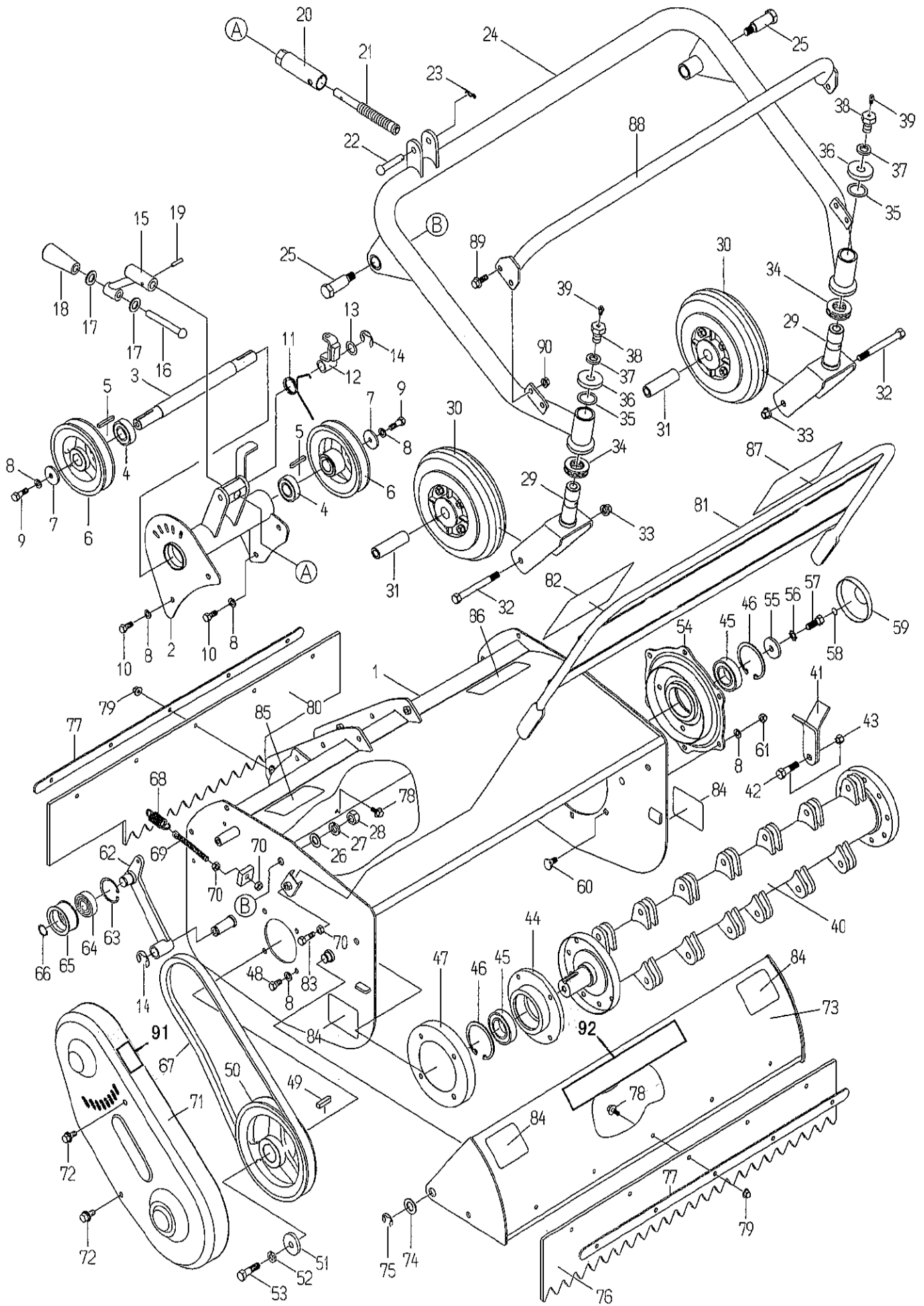

**FIG. 4 ROTARY COVER**

Ref.	Parts No.	Parts Name	Quantity	Remarks
			HRH	
			801 FE290D	
1	0204-60110	Rotary Cover CMP	1	
2	0204-40200	Supporter Pipe CMP	1	
3	0204-40100	Supporter Shaft	1	*2)
	0204-40110	Supporter Shaft	1	*3)
4	89-3115-060044	Bearing 6004 2RS	2	
5	89-2151-050350	Key 5x35	2	
6	80-1614-636-00	Supporter Pulley	2	
7	83-1565-315-00	Washer 8x36x4.5	2	*2)
	83-1610-321-00	Washer 10*36*4.5	2	*3)
8	89-1750-080002	Spring Washer 8	16	*2)
	89-1750-080002	Spring Washer 8	14	*3)
	89-1750-100002	Spring Washer 10	2	*3)
9	89-1213-080252	Mini Hexagonal Bolt (8T) M8*25	2	*2)
	89-1213-100252	Mini Hexagonal Bolt (8T) M10*25	2	*3)
10	89-1213-080182	Mini Hexagonal Bolt (8T) M8*18	4	
11	80-1614-373-20	Knife Brake Spring	1	
12	80-1417-371-00	Knife Brake	1	
	0231-37100	Knife Brake	1	*1)
13	83-1020-363-00	Thrust Washer 16x24x1.0	1	
14	89-2521-000150	E-type Ring 15	2	
15	84-1723-739-00	Cutting Height Adjusting Handle	1	
16	83-1713-166-00	Round Head Pin 10x80	1	
17	89-1711-100002	Flat Washer 10	2	
18	83-1210-425-00	Lever Grip 10	1	
19	89-2111-050022	Spring Pin 5x22	1	
20	80-1614-742-10	Height Adjusting Bolt Receiver	1	
21	80-1614-724-10	Height Adjusting Bolt CMP	1	
22	89-2181-100502	Flat Head Pin 10x50	1	
23	89-2131-100002	R Pin 10	1	
24	0204-61100	Front Arm CMP	1	
25	80-1610-714-00	Front Arm Setting Shaft	2	
26	89-1711-120002	Flat Washer 12	2	
27	89-1750-120002	Spring Washer 12	2	
28	83-1610-192-00	Hexagonal Nut(slender) M12 P=1.25	2	
29	80-1614-725-20	Front Fork CMP	2	
30	80-1614-727-00	Front Wheel	2	
31	80-1614-726-00	Front Wheel Collar	2	
32	89-1211-100952	Mini Hexagonal Bolt M10*95	2	
33	89-1543-100002	Mini Hexagonal Nut(SW) M10	2	
34	89-3370-051105	Thrust Bearing 51105	2	
35	83-1783-376-00	Thrust Washer 25x34x1.0	2	
36	84-1783-729-00	Dust Cover	2	
37	89-1750-140002	Spring Washer 14	2	
38	84-1783-791-00	Grease Nipple Bolt	2	
39	83-1415-975-00	Grease Nipple M6	2	
40~43	0204-50000	Knife Drum ASSY	1	
40	0204-50100	Knife Drum CMP	1	
41	80-1610-821-00	Hammer Knife Blade	46	
42~43	83-1610-835-00	Knife Setting Bolt Set	23	
44	80-1610-804-00	BB Case	1	
45	89-3115-062064	Bearing 6206 2RS	2	
46	89-2512-000620	Snap Ring 62	2	

**Fig. 4 ROTARY COVER**

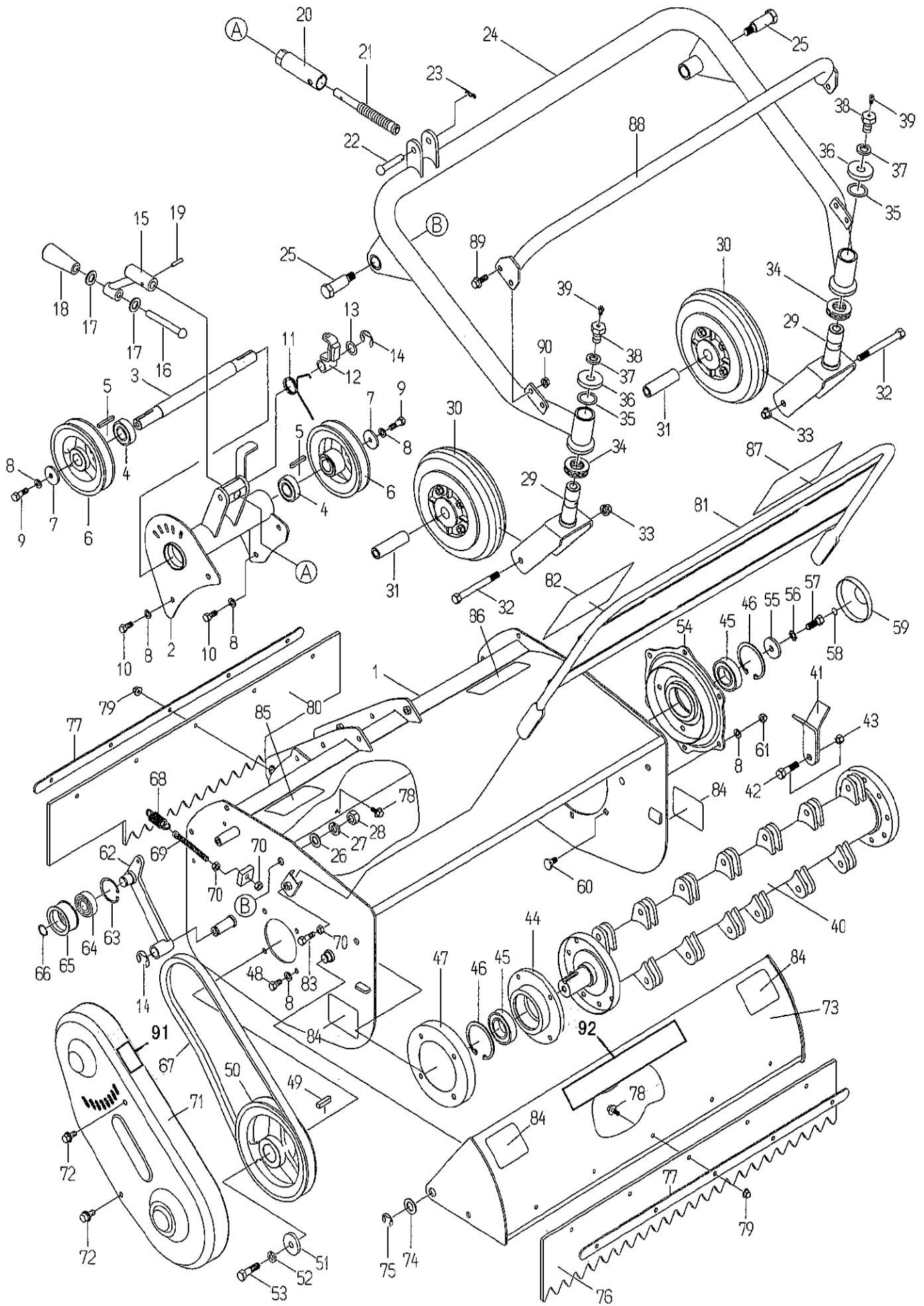



**FIG. 4 ROTARY COVER**

Ref.	Parts No.	Parts Name	Quantity	Remarks
			HRH	
			801 FE290D	
47	80-1612-813-00	Dust Cover	1	
48	89-1213-080162	Mini Hexagonal Bolt (8T) M8*16	4	
49	89-2151-070300	Key 7x30	1	
50	80-1614-634-20	Knife Pulley 155	1	
51	83-1610-322-00	Washer 10x36x6	1	
52	89-1750-100002	Spring Washer 10	1	
53	83-1610-125-00	Hexagonal Bolt(8T) M10x35	1	
54	80-1614-804-20	Knife Shaft BB Case CMP	1	
55	83-1610-321-00	Washer 10x36x4.5	1	
56	89-1812-100002	Tooth Washer 10	1	
57	83-1610-124-00	Hexagonal Bolt(8T) M10x25(left screw)	1	
58	80-1610-919-00	Label for Left Screw	1	
59	80-1614-810-00	BB Case Cover	1	
60	80-1614-705-00	Flat Head Bolt M8x18	6	
61	89-1671-080042	Mini Bag Nut M8	6	
62	80-1614-632-00	Front Tension Arm CMP	1	
63	89-2512-000400	Snap Ring 40	1	
64	89-3115-062034	Bearing 6203 2RS	1	
65	83-1032-765-00	Tension Pulley	1	
66	89-2511-000170	Snap Ring 17	1	
67	89-6123-003902	V Belt LB-39 W800	1	
68	80-1614-315-00	Return Spring	1	
69	80-1182-527-00	Tension Pulling Bolt	1	
70	89-1611-080042	Mini Hexagonal Nut M8	4	
71	80-1614-694-10	Knife Belt Cover	1	
72	89-1233-080162	Mini Hexagonal Bolt (PWSW) M8*16	2	
73	0204-60300	Front Cover CMP	1	
74	83-1110-332-00	Washer 15x26x2.3	2	
75	89-2521-000120	E-type Ring 12	2	
76	0204-60400	Front Flapper	1	
77	0204-70600	Flapper Holder	2	
78	89-1137-060152	Hexagonal Bolt(PW) M6*15	12	
79	83-1575-189-00	Flange Cap Nut M6	12	
80	0204-60500	Rear Flapper	1	
81	0204-60700	Safety Cover	1	
82	80-1614-906-00	Label, Safety Cover	1	
83	89-1211-080252	Mini Hexagonal Bolt M8*25	2	
84	83-1613-907-00	Label, Caution for Hand and Leg	4	*5)
	83-1613-907-10	Label, Caution for Hand and Leg	4	*1) *6)
85	83-1415-912-00	Label, Caution for Hitting Object	1	*5)
86	83-1415-913-00	Label, Eye Guard	1	*5)
87	80-1484-A47-00	Label, Caution(large)	1	*5)
	0223-76100	Label, Caution(large)	1	*1) *6)
88	0204-61200	Front Bumper	1	
89	89-1253-080202	Mini Flange Bolt(8T) M8*20	4	
90	89-1543-080002	Mini Hexagonal Nut (SW) M8	4	
91	80-1488-928-10	Label, Caution for Pinching	1	*6)
92	83-1050-901-00	Label, OREC	1	

MEMO